

MCX RIGHT ANGLE SOLDER / CRIMP PLUG 45-105-D6-AB

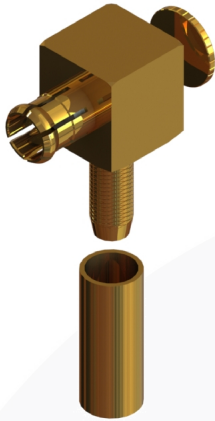

images for illustration purposes only

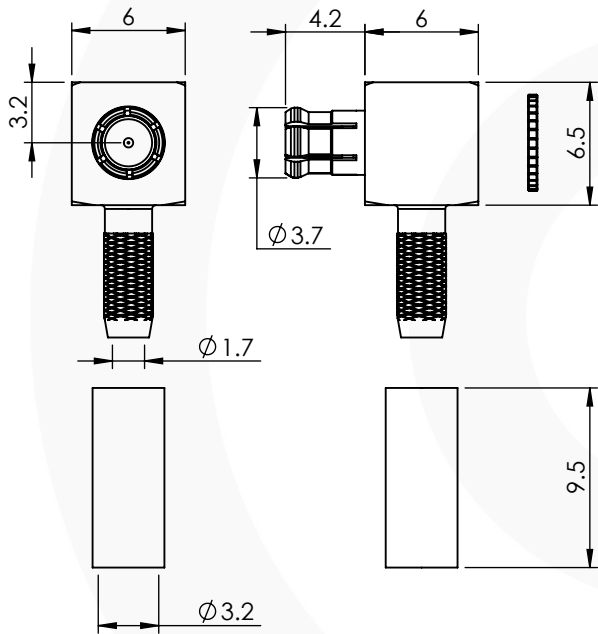

Suitable for Cables:

(AB) RG179, RG187, Belden 179DT

Stripping Dimensions

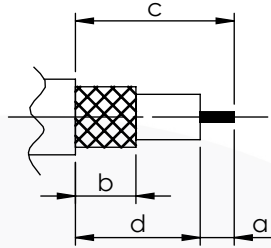

a = 2 mm
b = 7 mm
c = 11.7 mm
d = 9.7 mm

* CUT FOIL TO DIM. "b"

Assembly Procedure:

Tooling

Centre Contact: Solder Tool No: Solder

Crimp Sleeve: Hex 3.25mm A/F Tool No: HTS-43

Alignment Tool: Not Applicable Extraction: Not Applicable

Environmental Specification

Operating Temp: -55 to +155 Deg C.

IP Rating (Mated): NONE

Electrical Specification

Impedance: 75 Ohm

Frequency: 0-6 GHz

Dielectric W/V: 750 Veff

Insulation res: 1000 M-Ohm

Mechanical Specification

Contact Retention: 10 N min

Cable Retention: 50 N min

Mating cycles: 500

Weight: 2.05 g

Connector Interface

image for illustration purposes only

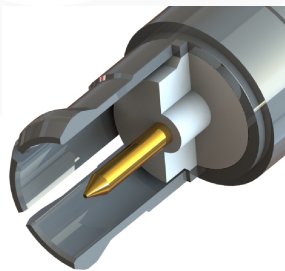

6	OUTER CONTACT	PHOSPHOR BRONZE	GOLD
5	CAP	BRASS	GOLD
4	CRIMP SLEEVE	BRASS	GOLD
3	INSULATOR	PTFE	N/A
2	CENTRE CONTACT	PHOSPHOR BRONZE	GOLD
1	BODY	BRASS	GOLD
ITEM	DESCRIPTION	MATERIAL	PLATING

A4	SHEET 1 OF 1	DIMENSIONS ARE IN MILLIMETRES		
REVISION :	A00	NAME	SIGNATURE	DATE
ISSUE :	1	DRAWN	I.G.	24/08/18
		CHK'D	G.E.	17/08/18
		APPV'D		
6-8 COLNE ROAD, TWICKENHAM, MIDDLESEX. TW1 4JR THE INFORMATION IS GIVEN AS AN INDICATION ONLY AND IS SUBJECT TO CHANGE WITHOUT NOTICE. IN THE CONTINUAL GOAL TO IMPROVE OUR PRODUCTS, WE RESERVE THE RIGHT TO MAKE ANY MODIFICATIONS NECESSARY WITHOUT PRIOR NOTICE.				