

TNC BULKHEAD CRIMP/CRIMP JACK

13-256-A0-AD

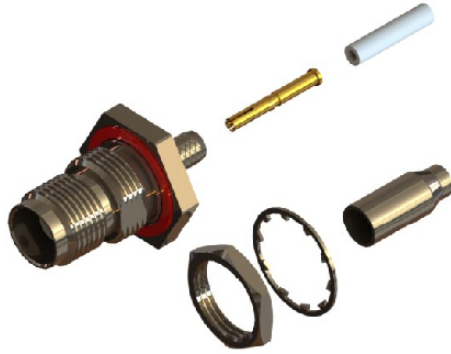

images for illustration purposes only

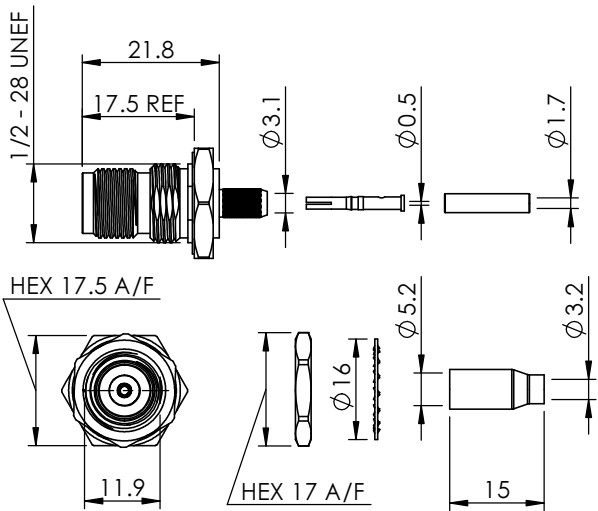

RECOMMENDED MOUNTING DIMENSIONS

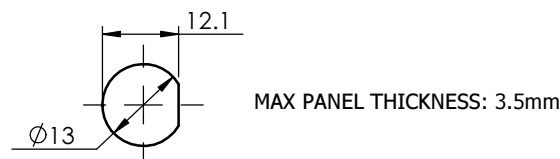

Suitable for Cables:

RG316, RG174, RG188, LMR100, WBC100, URM95, KX3, KX22

Stripping Dimensions

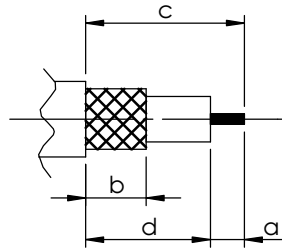

- a = 4.0 mm
- b = 10.0 mm
- c = 18.0 mm
- d = 14.0 mm

Assembly Procedure: AP002

Tooling

Centre Contact: Hex 1.72mm A/F Tool No: 336A

Crimp Sleeve: Hex 5.41mm A/F Tool No: 336A

Environmental Specification

Operating Temp: -30 to +70 Deg C.
IP Rating (Mated): IP 67

Electrical Specification

Impedance: 50 Ohm
Frequency: 0-1 GHz
Dielectric W/V: 1500 Veff
Insulation res: 4000 M-Ohm

Mechanical Specification

Contact Retention: 27 N min
Cable Retention: 40 N min
Mating cycles: 500
Weight: 22.65 g

Connector Interface

image for illustration purposes only



Performance

- 20.2 dB @ 1.0 GHz
- 15.9 dB @ 2.0 GHz
- 11.0 dB @ 3.0 GHz
- 6.9 dB @ 4.5 GHz

Return Loss Graph

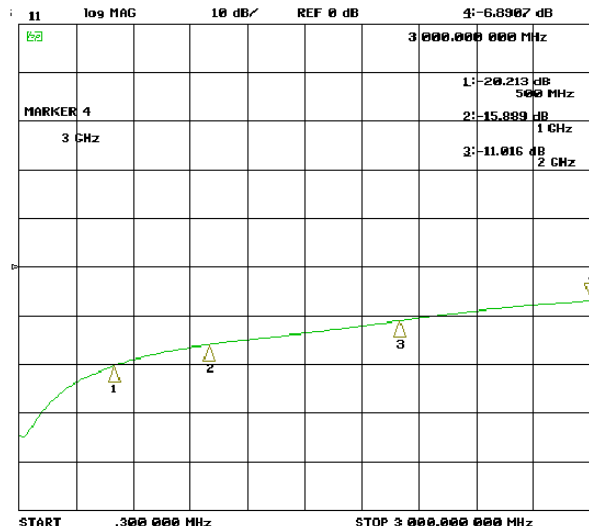

ITEM	DESCRIPTION	MATERIAL	PLATING
9	CRIMP SLEEVE	BRASS	NICKEL
8	PUSHER SLEEVE	DELTRIN	N/A
7	CENTRE CONTACT	PHOSPHOR BRONZE	GOLD
6	NUT	BRASS	NICKEL
5	WASHER	BRASS	NICKEL
4	GASKET	SILICONE	N/A
3	BACK BODY	BRASS	NICKEL
2	INSULATOR	DELTRIN	N/A
1	BODY	BRASS	NICKEL

A4	SHEET 1 OF 1		DIMENSIONS ARE IN MILLIMETRES		
REVISION :	A02	NAME	SIGNATURE	DATE	
ISSUE :	1	DRAWN	IG	28/06/2011	
		CHK'D	GE	28/06/2011	
		APPV'D			
<p>6-8 COLNE ROAD, TWICKENHAM, MIDDLESEX. TW1 4JR</p> <p>THE INFORMATION IS GIVEN AS AN INDICATION ONLY AND IS SUBJECT TO CHANGE WITHOUT NOTICE. IN THE CONTINUAL GOAL TO IMPROVE OUR PRODUCTS, WE RESERVE THE RIGHT TO MAKE ANY MODIFICATIONS NECESSARY WITHOUT PRIOR NOTICE.</p>					