

© 2008. THIS DOCUMENT IS THE PROPERTY OF COAX CONNECTORS LTD. REPRODUCTION OR COMMUNICATION IN ANY FORM TO A THIRD PARTY IS PROHIBITED WITHOUT PRIOR WRITTEN CONSENT

WEBSITE
VIDEO No.

DO NOT SCALE DRAWING



DATA SHEET

SHEET 1 OF 1

Electrical Specification

Impedance: 50 Ohm
 Frequency: TBC
 Dielectric W/V: TBC
 Insulation res: TBC

Mechanical Specification

Centre contact retention
 Axial Force: TBC
 Cable Retention: N/A
 Mating cycles: -

Environmental Specification

Operating Temp: -35 to +70 Deg C

Tooling

Centre Contact: N/A
 COAX Tool No:
 Crimp Sleeve: N/A
 COAX Tool No:

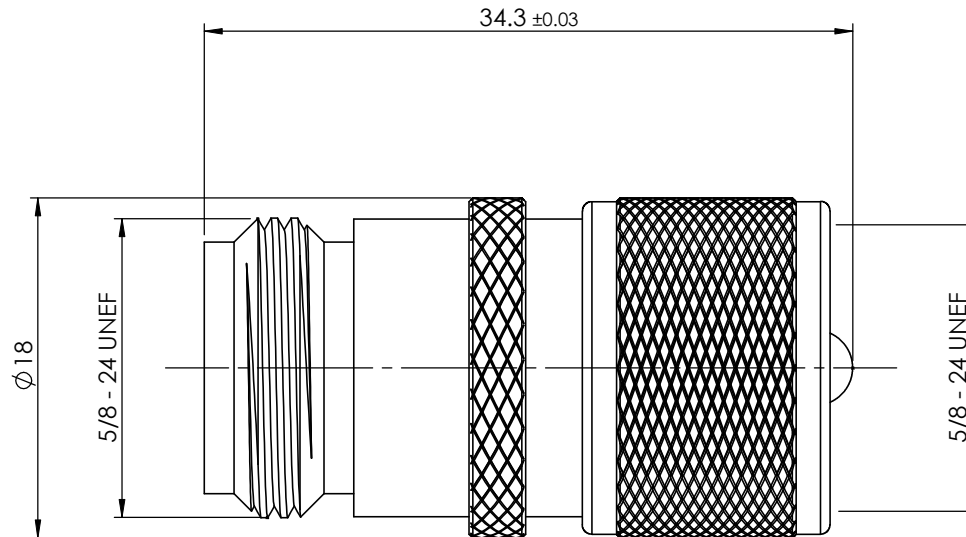
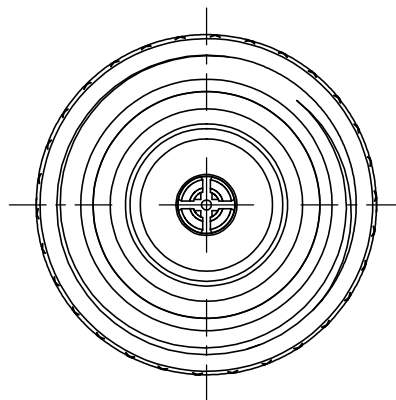

COAX CONNECTORS LTD
 6-8 COLNE ROAD, TWICKENHAM,
 MIDDLESEX. TW1 4JR

Description N TYPE JACK - UHF PLUG ADAPTOR.

Part Number 74-2025-514

REVISION
 A00

A4	DIMENSIONS ARE IN MILLIMETERS		
	NAME	SIGNATURE	DATE
DRAWN	GE		25/01/2010
CHK'D	CM		25/01/2010
APPV'D			

THE INFORMATION IS GIVEN AS AN INDICATION ONLY AND IS SUBJECT TO CHANGE WITHOUT NOTICE. IN THE CONTINUAL GOAL TO IMPROVE OUR PRODUCTS, WE RESERVE THE RIGHT TO MAKE ANY MODIFICATIONS NECESSARY WITHOUT PRIOR NOTICE.

7			
6			
5	COUPLING NUT	BRASS	NICKEL
4	WASHER	BRASS	N/A
3	CENTRE CONTACT	BRASS	GOLD
2	INSULATOR	DELRIN	N/A
1	BODY	BRASS	NICKEL
ITEM	DESCRIPTION	MATERIAL	PLATING