

© 2008. THIS DOCUMENT IS THE PROPERTY OF COAX CONNECTORS LTD. REPRODUCTION OR COMMUNICATION IN ANY FORM TO A THIRD PARTY IS PROHIBITED WITHOUT PRIOR WRITTEN CONSENT

WEBSITE VIDEO No.

DO NOT SCALE DRAWING



Electrical Specification

Impedance: 50 Ohm
 Frequency: TBC
 Dielectric W/V: TBC
 Insulation res: TBC

Mechanical Specification

Centre contact retention
 Axial Force: 10N
 Cable Retention: N/A
 Mating cycles: 500

Environmental Specification

Operating Temp: -35 to +70 Deg C

Tooling

Centre Contact: N/A
 COAX Tool No:
 Crimp Sleeve: N/A
 COAX Tool No:

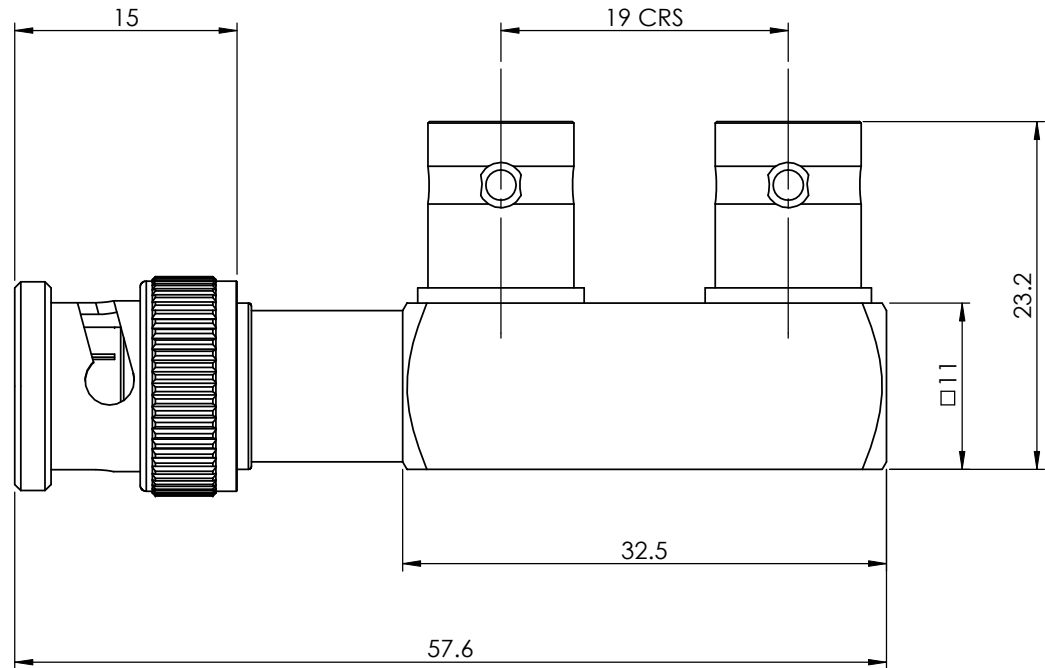
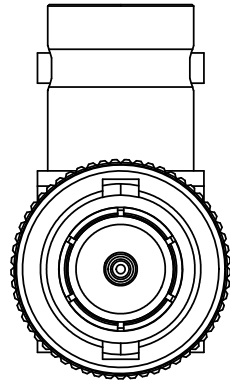

15	INSULATOR	PTFE	N/A	10	ADAPTOR	BRASS	NICKEL
14	WASHER	BRASS	NICKEL	9	INSULATOR	PTFE	N/A
13	FEMALE CONTACT	BRASS	GOLD	8	WASHER	Fe	NICKEL
12	BODY	BRASS	NICKEL	7	SPRING	SK5	NICKEL
11	INSULATOR	POM	N/A	6	RETAINING RING	SK5	NICKEL



COAX CONNECTORS LTD
 6-8 COLNE ROAD, TWICKENHAM,
 MIDDLESEX. TW1 4JR

REVISION : DA00
 ISSUE : 1

Description BNC PLUG TO 2 JACKS ("F" STYLE ADAPTOR)
Part Number 10-527-A3

DIMENSIONS ARE IN MILLIMETERS			
NAME	SIGNATURE	DATE	
DRAWN	GE	27/07/2010	
CHK'D	IG	27/07/2010	
APPV'D			

THE INFORMATION IS GIVEN AS AN INDICATION ONLY AND IS SUBJECT TO CHANGE WITHOUT NOTICE. IN THE CONTINUAL GOAL TO IMPROVE OUR PRODUCTS, WE RESERVE THE RIGHT TO MAKE ANY MODIFICATIONS NECESSARY WITHOUT PRIOR NOTICE.

5	GASKET	SILICONE	N/A
4	OUTER CONTACT	BRASS	NICKEL
3	INSULATOR	POM	N/A
2	MALE CONTACT	BRASS	GOLD
1	COUPLING NUT	ZINC DIE-CAST	NICKEL
ITEM	DESCRIPTION	MATERIAL	PLATING