

## TNC STRAIGHT FRONT MOUNT BULKHEAD SOLDER JACK

### 13-388-1-B3

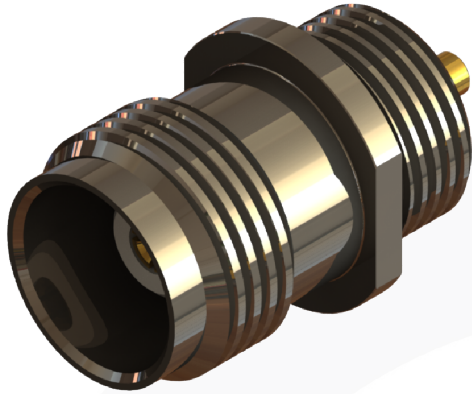

images for illustration purposes only

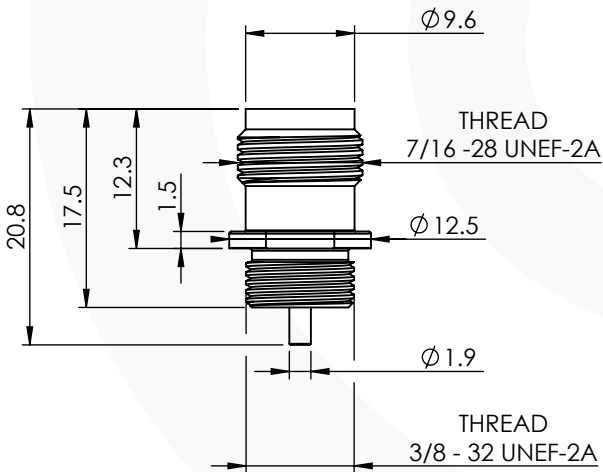
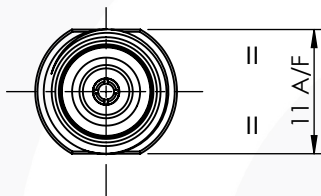

### Tooling

Centre Contact: Solder

Tool No: Solder

Crimp Sleeve: Not Applicable

Tool No: Not Applicable

Alignment Tool: Not Applicable

Extraction: Not Applicable

### Environmental Specification

Operating Temp: -65 to +165 Deg C.

IP Rating (Mated): IP 40

### Electrical Specification

Impedance: 50 Ohm

Frequency: 0-11 GHz

Dielectric W/V: 1500 Veff

Insulation res: 5000 M-Ohm

### Mechanical Specification

Contact Retention: 10 N min

Cable Retention: Not Applicable

Mating cycles: 500

Weight: 6.07 g

### Connector Interface

image for illustration purposes only

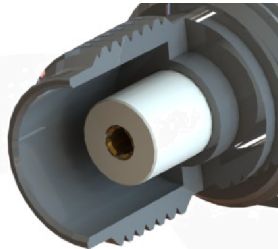

4	RETAINER	BRASS	NICKEL
3	INSULATOR	PTFE	N/A
2	CENTRE CONTACT	BERYLLIUM COPPER	GOLD
1	BODY	BRASS	NICKEL
ITEM	DESCRIPTION	MATERIAL	PLATING

<b>A4</b>	SHEET 1 OF 1	DIMENSIONS ARE IN MILLIMETRES		
REVISION :	A01	NAME	SIGNATURE	DATE
ISSUE :	1	DRAWN	G.E.	20/08/2020
		CHK'D	P.S.	20/08/2020
		APPV'D		
<b>6-8 COLNE ROAD, TWICKENHAM, MIDDLESEX. TW1 4JR</b>				
<small>THE INFORMATION IS GIVEN AS AN INDICATION ONLY AND IS SUBJECT TO CHANGE WITHOUT NOTICE. IN THE CONTINUAL GOAL TO IMPROVE OUR PRODUCTS, WE RESERVE THE RIGHT TO MAKE ANY MODIFICATIONS NECESSARY WITHOUT PRIOR NOTICE.</small>				